

REVISION RECORD			
REV.	CONTENT	MOD.	DATE
△	初版发行		

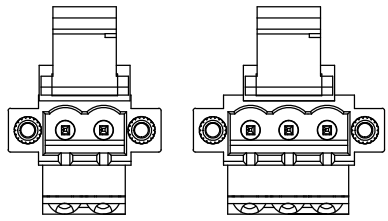

2P

3P

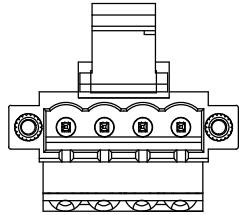

4P

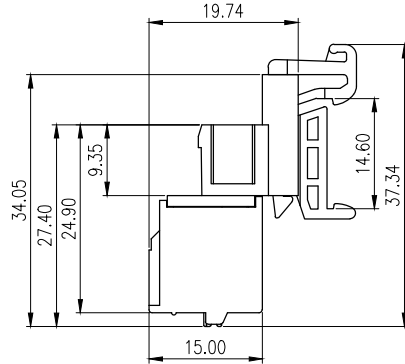
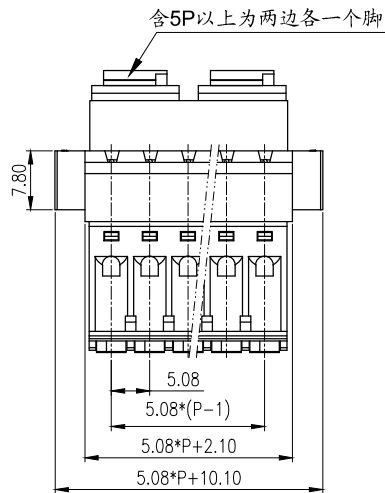
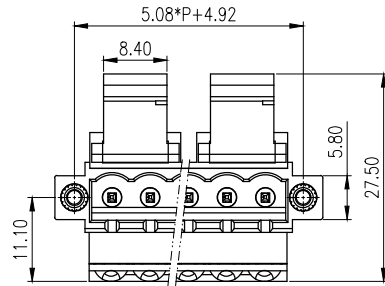

- NOTES1:
UL Standard:
1.Voltage Rating: 300V, Current Rating: 10A
- NOTES2:
1.Pitch : 5.08mm
2.Withstand Voltage : AC2500V for 1 minute
3.Using Temperature Range : - 40℃ ~ + 105℃
4.Suitable Electric Wire: 26-12AWG

- 技术要求1:
UL 标准:
1.额定电压: 300V, 额定电流: 10A
- 技术要求2:
1.间距: 5.08mm
2.耐电压值: AC2500V/min
3.使用条件: -40℃~+105℃
4.适用线规: 26-12AWG

7	LC15-脚	1067T0Y00AV	1-2	PA66-V0				
6	LZ1-耳朵螺母	SM00B250000V	2	黄铜				
5	LC60-5.08五金件	2083B0001AV	P	磷青铜	镀亮锡			
4	LC6-5.08-弹片	F2A0DLC658BV	P	不锈钢				
3	LC6-5.08-按钮	1020D0Y01AV	P	POM				
2	LC26UMG-5.08-盖板	2085N0YXXAV	1	PA66-V0				
1	LC6-5.08-本体	1020A0YXXAV	1	PA66-V0				
NO.	NAME OF PART	NO. OF PART	Q' TY	MATERIAL	NOTES			
DES.	CMZ	DATE	2025/03/26	UNITS	MM	THIRD ANGLE PROJECTION	SHEET	
CHK.		DATE		SIZE	A4		1 of 1	
APP.		DATE		SCALE	1:1		DWG NO.	SP-2-208502
上海联捷电气有限公司 Shanghai Elinker Electric Co., LTD				TITLE	LC25UMG-5.08-XXP-1Y-00A LC25UMG-5.08-成品			

	pitch dimension			Nominal dimension					— /
	over 0	over 6	over 10	over 0	over 30	over 60	over 100	over 150	
variable range	to 6	to 10	to 24	to 30	to 60	to 100	to 150		
Tolerance	±0.1	±0.15	±0.25	±0.2	±0.3	±0.5	±0.7	±1.0	